



Application guidelines

Maneurop[®] reciprocating compressors NTZ - R404A - R507



Maneurop® reciprocating compressors5
 Features 5

Specifications.....6
 Technical specifications and nominal ratings 6
 Versions..... 6
 Compressor reference 6

Dimensions7
 1 cylinder 7
 2 cylinders..... 8
 4 cylinders..... 9

Electrical connections and wiring 10
 Voltage application range 10
 Single phase electrical characteristics 10
 Nominal capacitor values and relays..... 10
 Single phase motor protection and suggested wiring diagram..... 10
 Single phase PSC wiring with trickle circuit 11
 Single phase CSR wiring with trickle circuit 11
 Single phase CSR wiring without trickle circuit..... 11
 Three phase electrical characteristics 12
 Three phase motor protection and suggested wiring diagram..... 12
 Wiring diagram with pump-down cycle..... 12
 Wiring diagram without pump-down cycle..... 13
 IP rating..... 13
 Motor protection..... 13
 Voltage unbalance..... 13

Approval and certifications 14
 Approvals and certificates..... 14
 Pressure Equipment Directive 97/23/EC..... 14
 Low voltage directive 2006/95 EC..... 14
 Machine directive 2006/42/EC 14
 Internal free volume..... 14

Operating conditions 15
 Refrigerants and lubricants 15
 Operating envelope R404A / R507..... 15
 Discharge temperature protection 15
 Operating limits 16

System design recommendations 17
 Piping design 17
 Suction line..... 17
 Discharge line..... 17
 Oil charge and oil separator 18
 Filter driers..... 18
 Suction pressure control..... 18
 Suction line heat exchanger..... 18
 Cycle rate limit..... 19
 Liquid refrigerant control and charge limits 19
 Off-cycle migration..... 19
 Liquid floodback during operation 19
 Crankcase heater..... 20
 Liquid line solenoid valve & pump-down 20
 Suction accumulator..... 20

Sound and vibration management	21
Sound	21
Vibration	21
Installation and service	22
System cleanliness	22
Compressor handling, mounting and connection	22
Compressor connection to the system	23
System pressure test	23
Leak detection	24
Vacuum pump-down and dehydration procedure	24
Start-up	24
Refrigerant charging	24
Oil charge and oil level	25
Installation checks	25
Ordering information and packaging	26
Code numbers	26
Packaging	26
Accessories	27

Features

The Maneurop® NTZ series from Danfoss Commercial Compressors is a range of hermetic reciprocating compressors for low evaporating temperature applications. These compressors replace the former LTZ range.

The NTZ series is engineered as a true low temperature compressor, optimised at -35°C with an extended evaporating temperature range from -45°C up to -10°C. The compressors can be operated at a return gas temperature (suction gas temperature) of 20°C even at low evaporating temperatures.

A liquid injection system is not required. All components are of high quality and precision to assure a long product life.

NTZ compressors have a large internal free volume that helps to reduce the risk of liquid hammering. The electrical motor is fully suction gas cooled which means that no additional body cooling is required and it allows the compressor to be insulated with an acoustic hood when the installation requirements call for extra low sound characteristics.

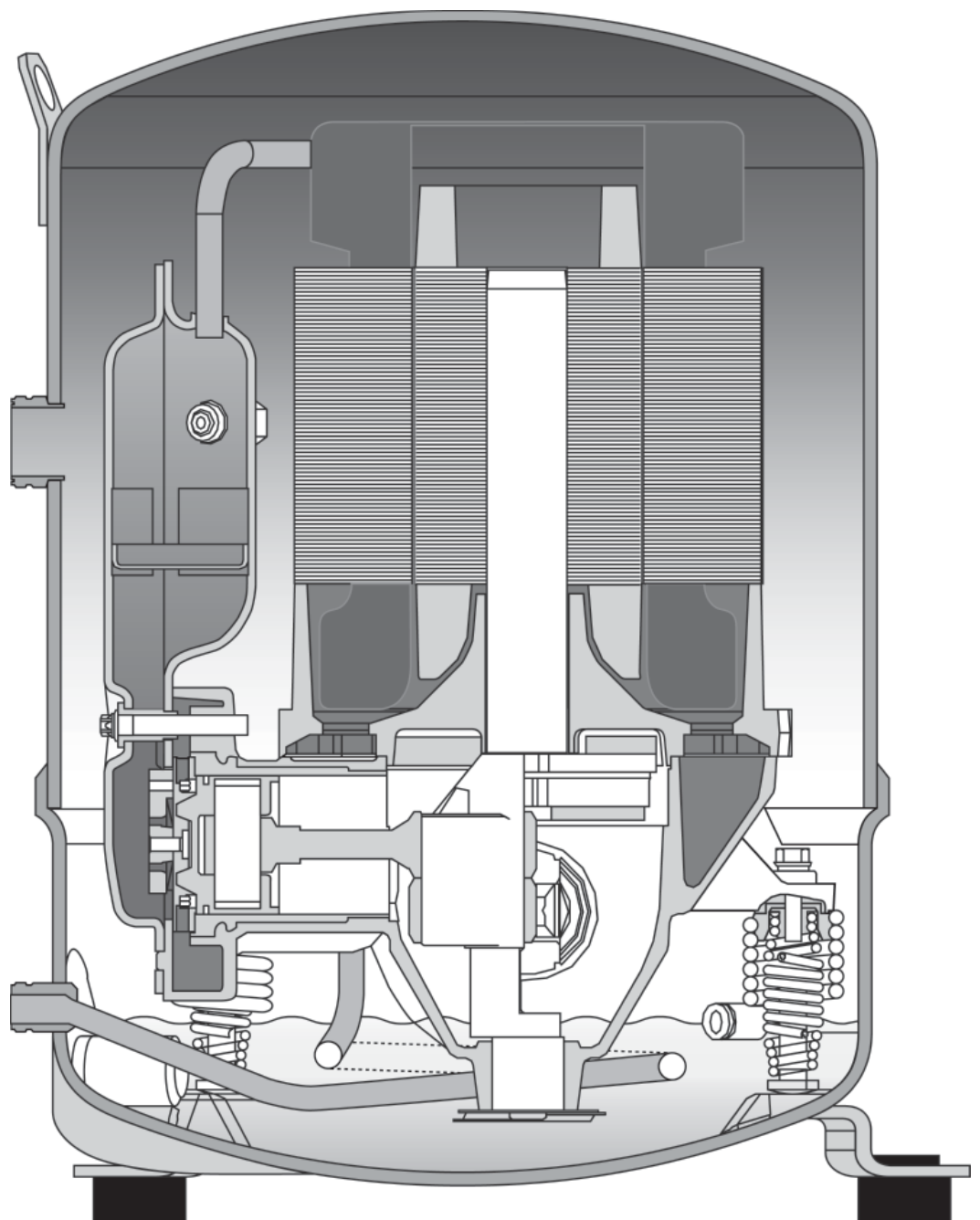

Technical specifications and nominal ratings

Compressor model	Swept volume cm ³ /rev	Displacement		Nominal ratings*				Number of cylinders	Oil charge litre	Net weight kg
		50 Hz 2900 rpm m ³ /hr	60 Hz 3500 rpm m ³ /hr	50 Hz		60 Hz				
				Cooling capacity W	COP W/W	Cooling capacity W	COP W/W			
NTZ048	48	8.4	10.1	995	1.15	1190	1.13	1	0.95	21
NTZ068	68	11.8	14.3	1749	1.15	1870	1.10	1	0.95	23
NTZ096	96	16.7	20.2	2002	1.15	2395	1.16	2	1.8	35
NTZ108	108	18.7	22.6	2465	1.16	2788	1.10	2	1.8	35
NTZ136	136	23.6	28.5	3225	1.11	3739	1.12	2	1.8	35
NTZ215	215	37.5	45.2	4948	1.19	5886	1.19	4	3.9	62
NTZ271	271	47.3	57.0	6955	1.24	8058	1.21	4	3.9	64

(*) Motor code 4 operating conditions: R404A, Evap. temp.: -35°C, Cond. temp.: 40°C, RGT: 20°C, SC: 0K
 For full NTZ data details and capacity tables refer to Online Datasheet Generator: www.danfoss.com/odsg

Versions

Available equipment version:

- R1: Rotolock suction and discharge connections, 3/8" flare oil equalisation connection, threaded sight glass.

Compressor reference

(indicated on the compressor nameplate)

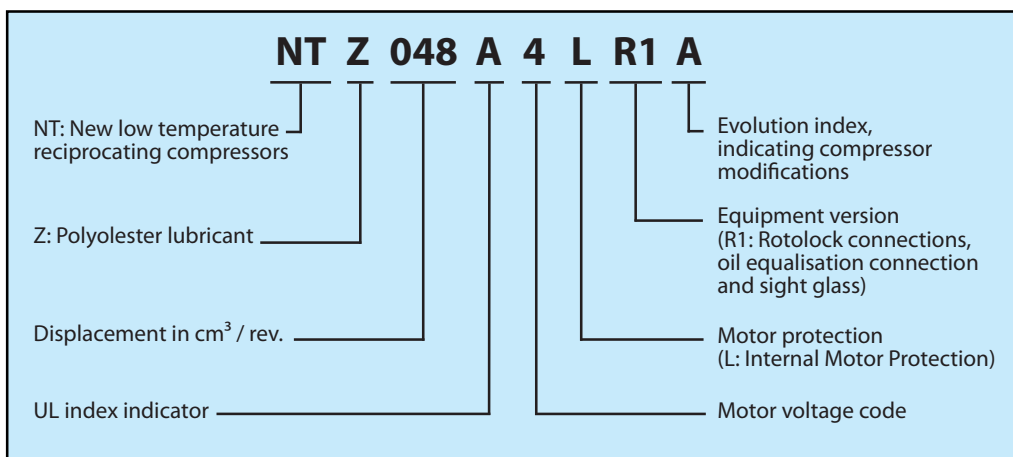

1 cylinder

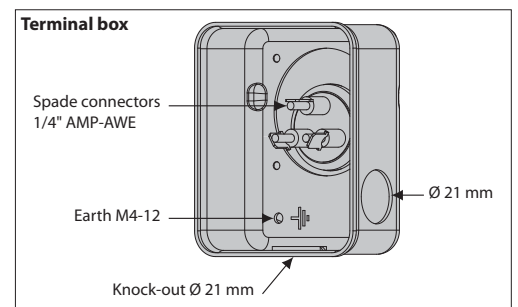
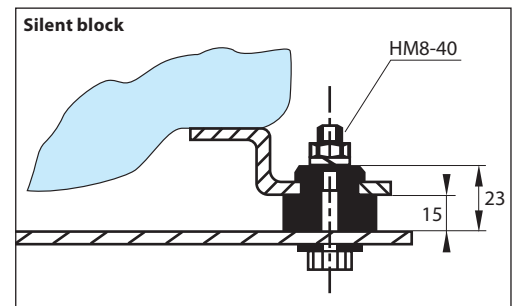
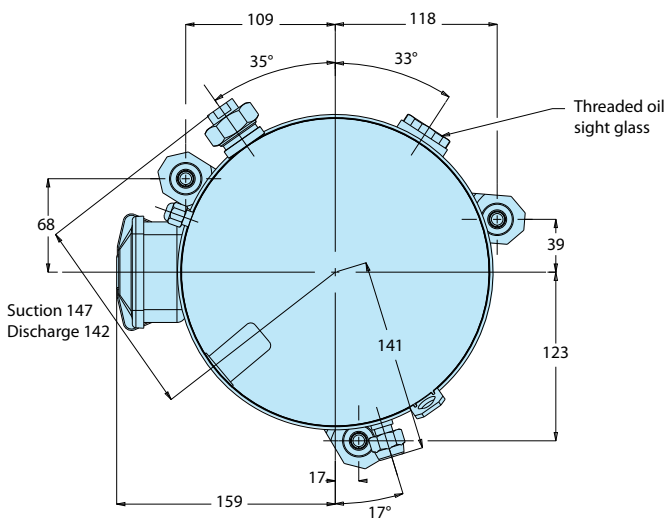
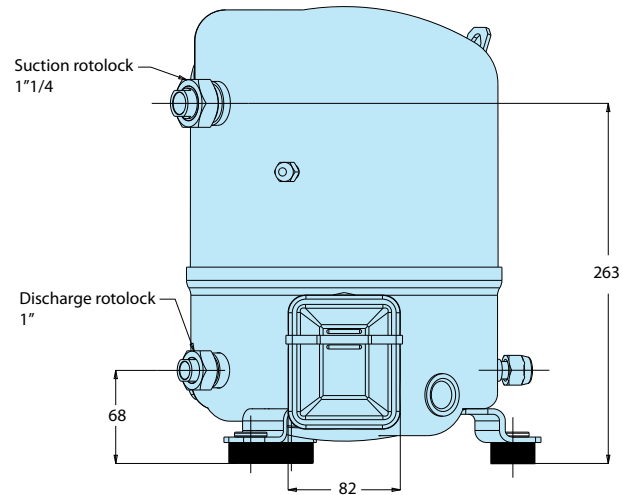
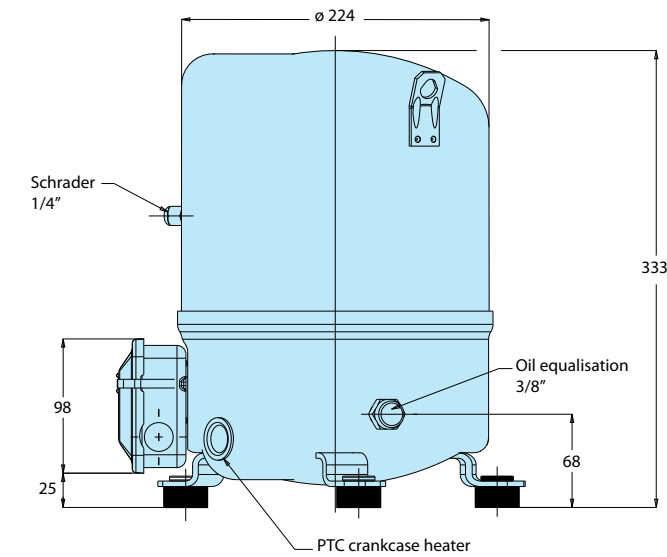

IP rating: 55 (with cable gland)

	Rotolock connections size		Pipe sizing		Rotolock valve	
	Suction	Discharge	Suction	Discharge	Suction	Discharge
NTZ048 NTZ068	1 1/4"	1"	5/8"	1/2"	V09	V06

2 cylinders

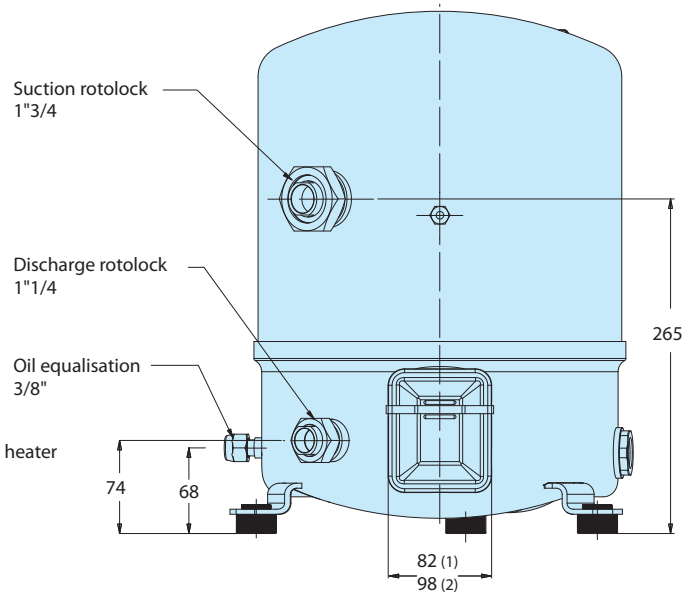
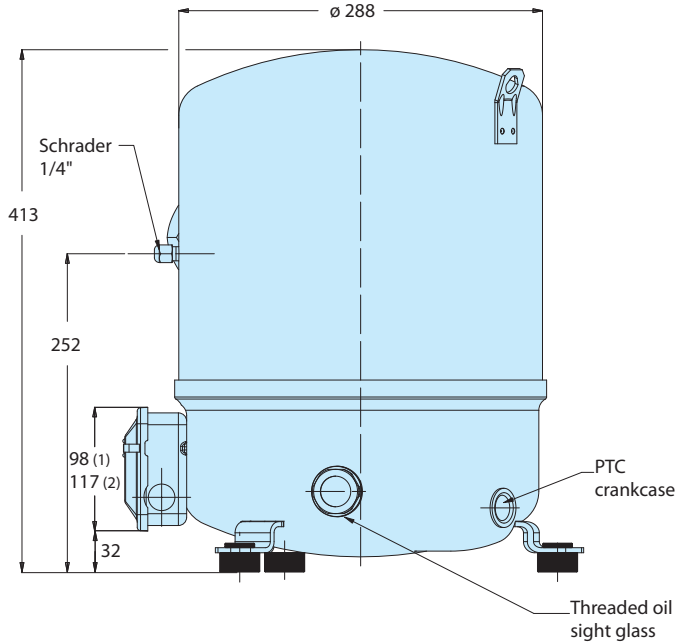

(1) NTZ096 - 108
(2) NTZ136-1

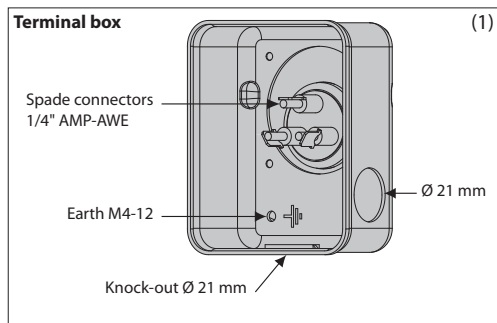
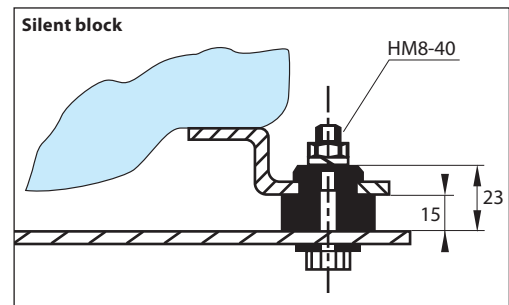
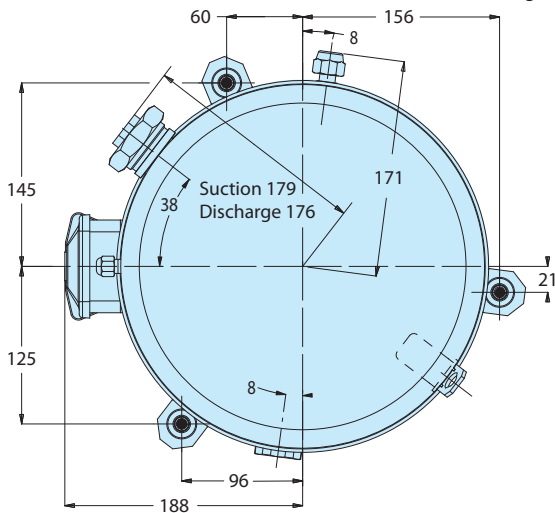

IP rating: 55 (with cable gland)

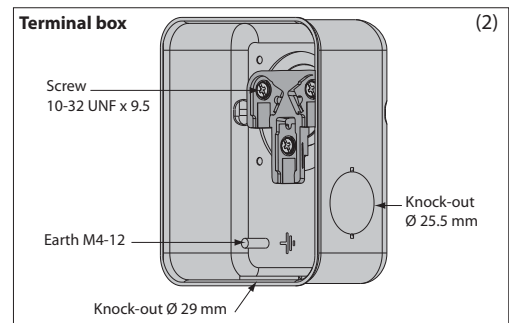

IP rating: 54 (with cable gland)

	Rotolock connections size		Pipe sizing		Rotolock valve	
	Suction	Discharge	Suction	Discharge	Suction	Discharge
NTZ096 - NTZ108	1"3/4	1"1/4	7/8"	3/4"	V07	V04
NTZ136	1"3/4	1"1/4	1"1/8"	3/4"	V02	V04

4 cylinders

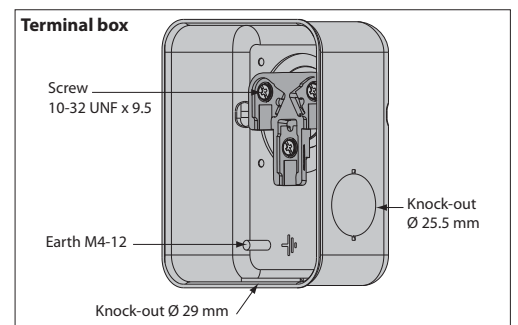
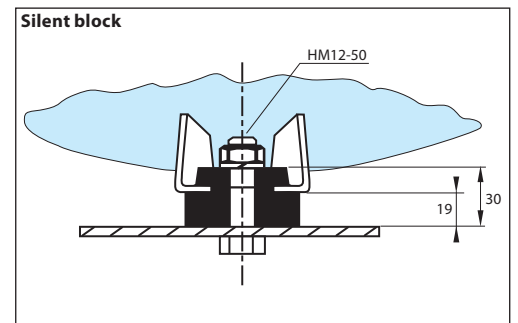
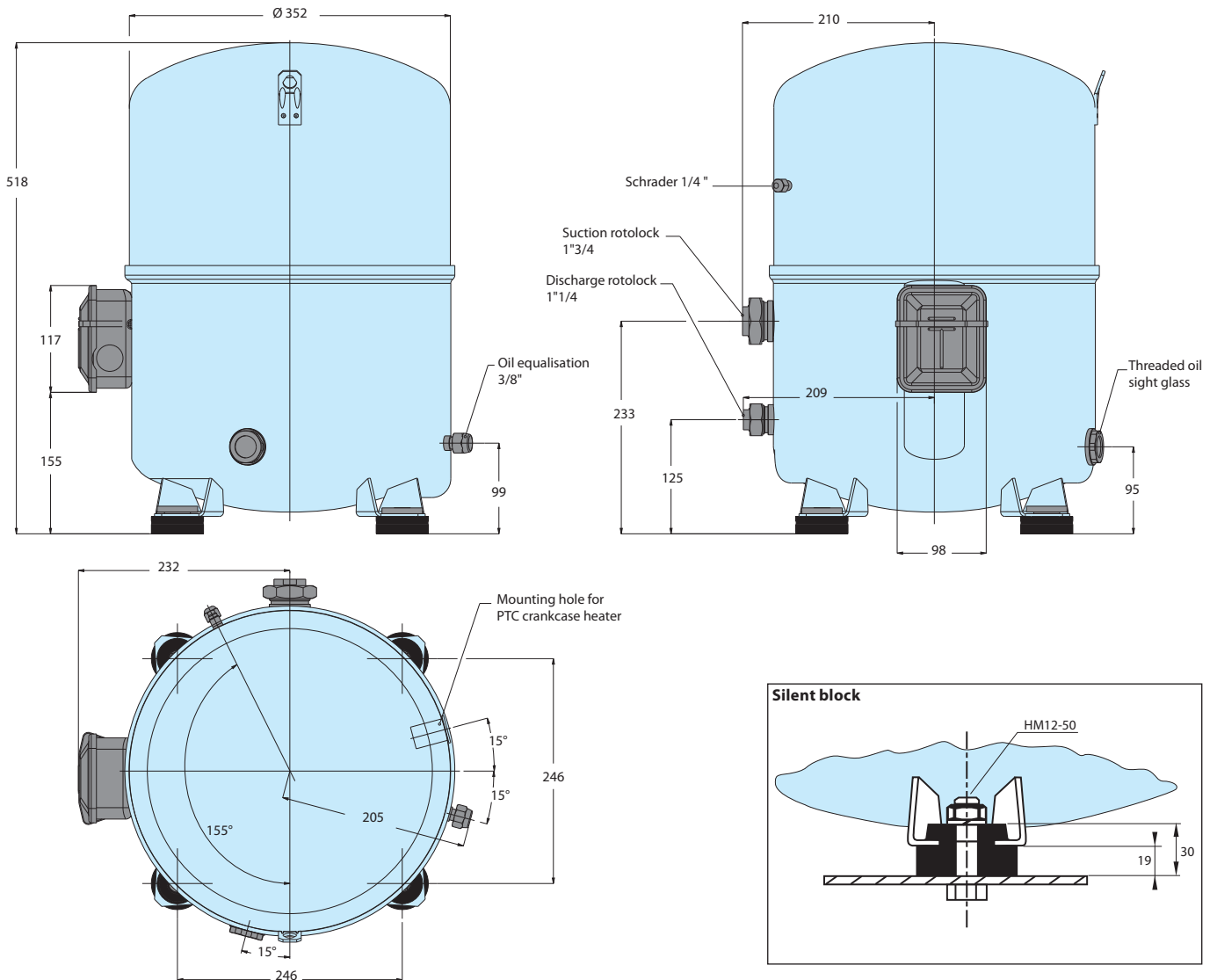

IP rating: 54 (with cable gland)

	Rotolock connections size		Pipe sizing		Rotolock valve	
	Suction	Discharge	Suction	Discharge	Suction	Discharge
NTZ215 - NTZ271	1 3/4	1 1/4	1 1/8"	3/4"	V02	V04

Voltage application range

Motor voltage code	Nominal voltage	Voltage application range
1	208-230 V / 1 / 60 Hz	187 – 253 V
3	200-230 V / 3 / 60 Hz	180 – 253 V
4	380-400 V / 3 / 50 Hz 460 V / 3 / 60 Hz	340 – 440 V (50 Hz) 414 – 506 V (60Hz)
5	230 V / 1 / 50 Hz	207 – 253 V
9	380 V / 3 / 60 Hz	342 – 418 V

Single phase electrical characteristics

Motor Code	LRA - Locked Rotor Current (A)		MCC - Maximum Continuous Current (A)		Winding resistance (Ω) (± 7 % at 20° C)			
	1	5	1	5	1		5	
Winding					run	start	run	start
NTZ048	43.7	37	13.2	11	1.32	4.16	1.62	3.95
NTZ068	72	53	21	17	0.94	2.01	1.05	3.19
NTZ096	97		31		0.45	1.84		
NTZ108	97		33		0.45	1.84		
NTZ136	140		41		0.36	1.73		

Nominal capacitor values and relays

	Models	PSC/CSR*		CSR only	
		Run capacitors (1)		Start capacitors (2)	Start relay
		(A) μF	(C) μF	(B) μF	
50 Hz	NTZ048	20	10	100	RVA6AMKL
	NTZ068	20	10	100	
60 Hz	NTZ048	15	10	100	
	NTZ068	25	25	135	
	NTZ096	30	15	135	
	NTZ108	30	15	135	
	NTZ136	30	15	135	

* PSC: Permanent Split Capacitor
 CSR: Capacitor Start Run
 (1) Run capacitors: 440 volts
 (2) Start capacitors: 330 Volts

Single phase motor protection and suggested wiring diagram

Single phase compressor motors are internally protected by a temperature / current-sensing bimetallic protector which senses the main and start winding current as well as motor winding temperature. If the motor were to be overloaded and the protector trips, it might take up to several hours to reset and restart the compressor.

The standard CSR wiring system provides additional motor torque at start-up, by the use of a start capacitor in combination with a run capacitor. The start capacitor is only connected during the starting operation and a potential relay disconnects it after the start sequence. This system can be used for refrigerant circuits with capillary tubes or expansion valves.

Single phase PSC wiring with trickle circuit

- IOL Motor protector
- A & C Run capacitors
- C Common
- S Start winding (auxiliary)
- R Run winding (main)

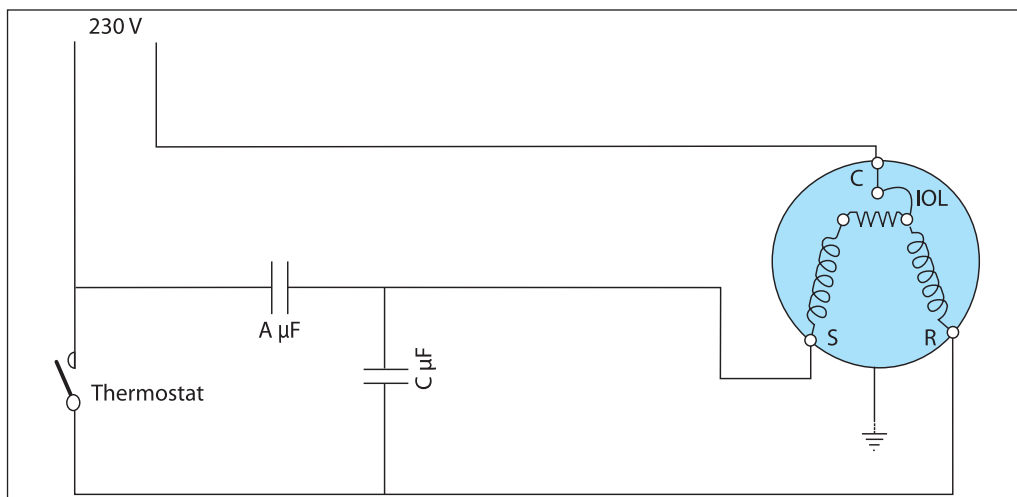

Single phase CSR wiring with trickle circuit

- IOL Motor protector
- A & C Run capacitors
- B Start capacitor
- C Common
- S Start winding (auxiliary)
- R Run winding (main)

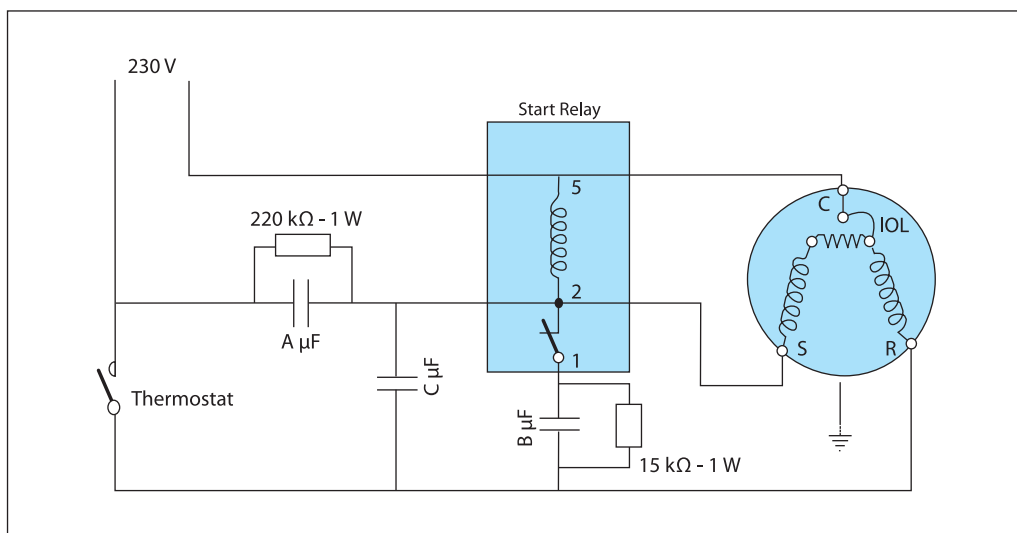

Single phase CSR wiring without trickle circuit

- IOL Motor protector
 - A + C Run capacitors
 - B Start capacitor
 - C Common
 - S Start winding (auxiliary)
 - R Run winding (main)
- Capacitors A and C are replaced by single capacitor of size A + C

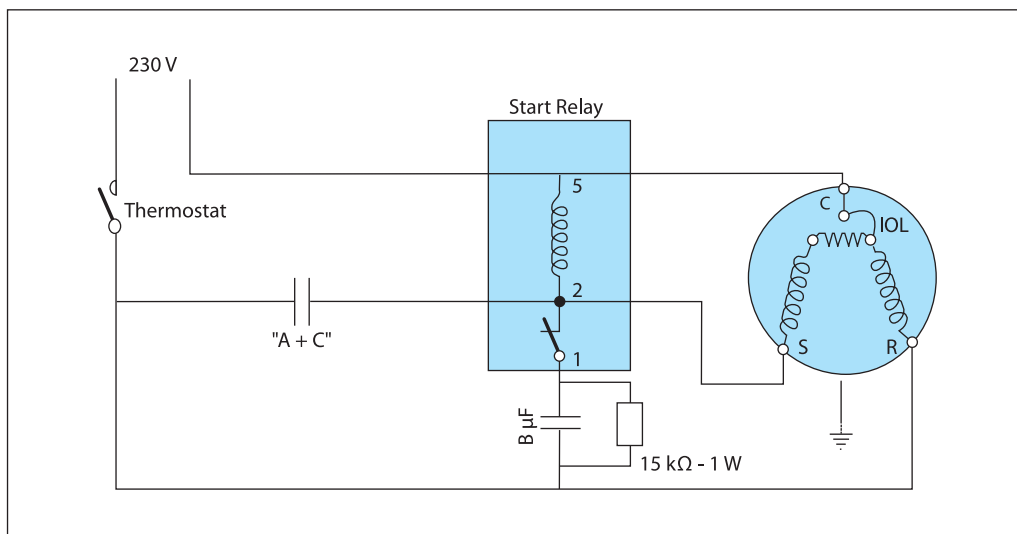

Three phase electrical characteristics

Compressor model	LRA (Locked Rotor Amp) A			MCC (Maximum Continuous Current) A			Winding resistance (between phases +/- 7% at 25°C) Ohm		
	3	4	9	3	4	9	3	4	9
NTZ048	32	16	22	10.1	4.8	5	2.80	11.55	13.10
NTZ068	48.5	25	29	14.8	8.4	8.5	1.58	7.11	9.70
NTZ096	72	32		20.4	10.1		1.20	5.03	
NTZ108	72	45	57	21.4	12.1	11	1.20	4.00	2.54
NTZ136	97.2	51	64	29	14.3	15	0.98	3.80	2.54
NTZ215	147.7	74	110	42.3	22.3	23	0.57	2.23	1.26
NTZ271	198	96	150	56.5	27.0	30	0.41	1.61	0.84

Three phase motor protection and suggested wiring diagram

- FU Fuses
- MS Main switch
- C1 Compressor contactor
- TH Thermostat
- EC External controls
- COMP Compressor
- PTC Crankcase heater
- IOL Internal overload line break

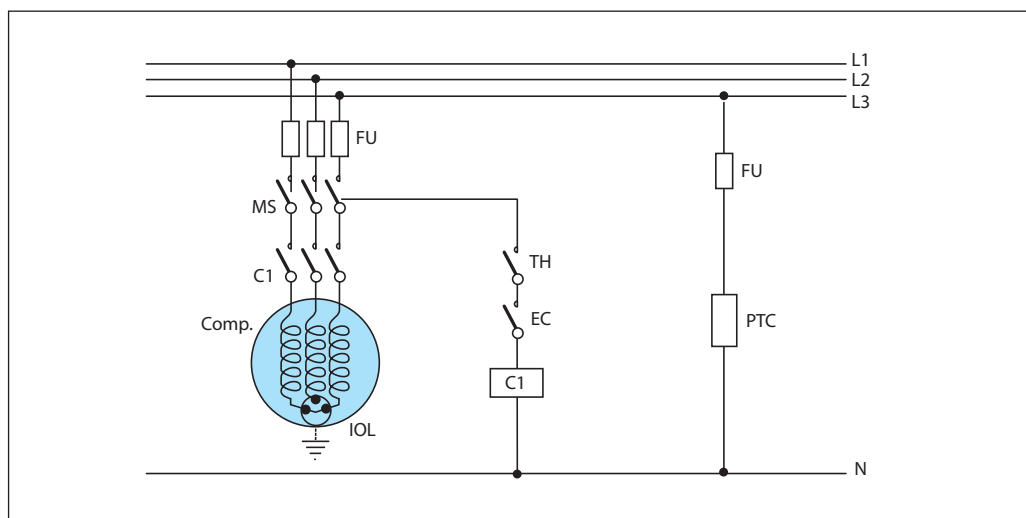

Wiring diagram with pump-down cycle

- Control device TH
- Optional short cycle timer (3 min) 180 s
- Control relay KA
- Liquid Solenoid valve LLSV
- Compressor contactor KM
- Safety lock out relay KS
- Pump-down control & L.P. switch BP
- H.P. switch HP
- Fused disconnect Q1
- Fuses F1
- Compressor motor M
- Discharge gas thermostat DGT

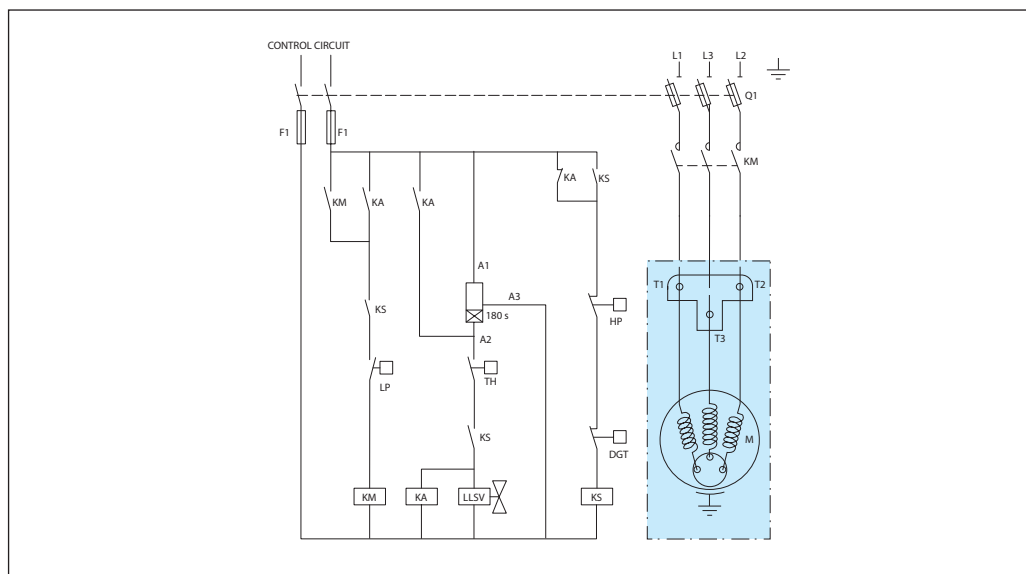

Wiring diagram without pump-down cycle

Control device	TH
Optional short cycle timer (3 min) 180 s	A1
Control relay	KA
Compressor contactor	KM
Safety lock out relay	KS
H.P. switch	HP
Fused disconnect	Q1
Fuses	F1
Compressor motor	M
Discharge gas thermostat	DGT

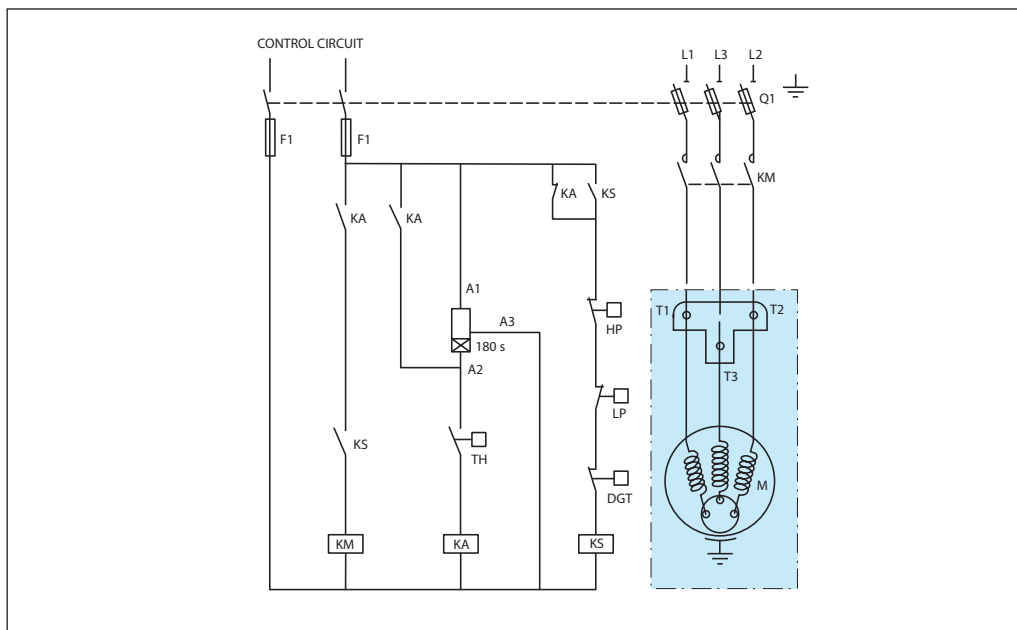

IP rating

The compressor terminal boxes IP rating according to CEI 529 are:
 IP55 for NTZ048 - 136
 IP54 for NTZ215 - 271.

The IP ratings are only valid when correctly sized cable glands of the same IP rating are applied.

IP 5 5

First numeral, level of protection against contact and foreign objects

- 5 Complete protection against contact and against harmful dust deposits

Second numeral, level of protection against water

- 4 Protection against water splashing from any direction
- 5 Protection against jets of water from any direction

Motor protection

Internal motor protection

Three phase compressors are internally protected by a temperature / current-sensing bimetallic protector, connected to the neutral point of the star-connected stator windings. This internal overload line break protects the motor against

overheating, current overload and locked rotor conditions. If the motor were to be overloaded and the protector trips, all 3-phases are cut out. It might take up to several hours to reset and restart the compressor.

Voltage unbalance

Operating voltage limits are shown in section "Voltage application range". The voltage applied to motor terminals must lie within these limits during both start-up and normal operation. The maximum allowable voltage unbalance is 2%. Voltage unbalance causes high amperage on one

or more phases, which in turn leads to overheating and possible motor damage.

The voltage unbalance is given by the following formula:

$$\% \text{ voltage unbalance: } \frac{|V_{avg} - V_{1-2}| + |V_{avg} - V_{1-3}| + |V_{avg} - V_{2-3}|}{2 \times V_{avg}} \times 100$$

V_{avg} = Mean voltage of phases 1, 2 and 3
 V_{1-2} = Voltage between phases 1 and 2

V_{1-3} = Voltage between phases 1 and 3
 V_{2-3} = Voltage between phases 2 and 3.

Approvals and certificates

Maneurop® NTZ compressors comply with the following approvals and certificates.

Certificates are listed on the product datasheets: <http://www.danfoss.com/odsg>

CE (European Directive)		All models
UL (Underwriters Laboratories)		Models with motor voltage code 1, 3 & 4, NTZ048 - 9 & NTZ068 - 9
CCC (China Compulsory Product Certification)		Models with motor voltage code 4 & 5.
Gost certificate (for Russia)		Models with motor voltage code 4 & 5.

Pressure Equipment Directive 97/23/EC

Products	NTZ 048 to 068	NTZ 096 to 271
Refrigerating fluids	Group 2	Group 2
Category PED	I	II
Evaluation module	out of the scope	D1
Service temperature - Ts	50°C < Ts > -35°C	50°C < Ts > -35°C
Service pressure - Ps	22.6 bar	22.6 bar
Declaration of conformity	PED005	PED005

Low voltage directive 2006/95 EC

Products	NTZ 048 to 271
Declaration of conformity ref. Low voltage Directive 2006/95/EC	Contact Danfoss

Machine directive 2006/42/EC

Products	NTZ 048 to 271
Manufacturer's declaration of incorporation ref. machines Directive 2006/42/EC	Contact Danfoss

Internal free volume

Products	Internal free volume without oil (litre)
NTZ 048 to 068	7,7
NTZ 096 to 136	16.5
NTZ 215 to 271	32

Refrigerants and lubricants

Maneurop® NTZ compressors are designed and optimised for refrigerants R404A and R507. The use of hydrocarbons is not authorised in NTZ compressors.

Only approved refrigerants and lubricants as listed in below table may be used.

Refrigerant	Type*	ODP**	Temp.glide*** (K)	Lubricant
R404A	HFC	0	0.7	160Z polyolester lubricant, factory charged (160SZ allowed alternatively)
R507			0	

*Type: HFC: Hydrofluorcarbon (no chlorine component, "long-term" zero-ODP alternative)

**ODP: Ozone Depletion Potential (base R11; ODP = 1)

*** Temperature glide: difference between saturated vapor temperature and saturated liquid temperature at constant pressure

Operating envelope R404A / R507

Because of their thermodynamic properties, R404A and R507 are especially suitable for low and medium temperature applications. Danfoss recommends the use of these refrigerants with NTZ compressors. Note that R404A has a small

temperature glide. It must therefore be charged in the liquid phase. For most other aspects however, this small glide may be neglected. R507 is an azeotropic mixture without temperature glide.

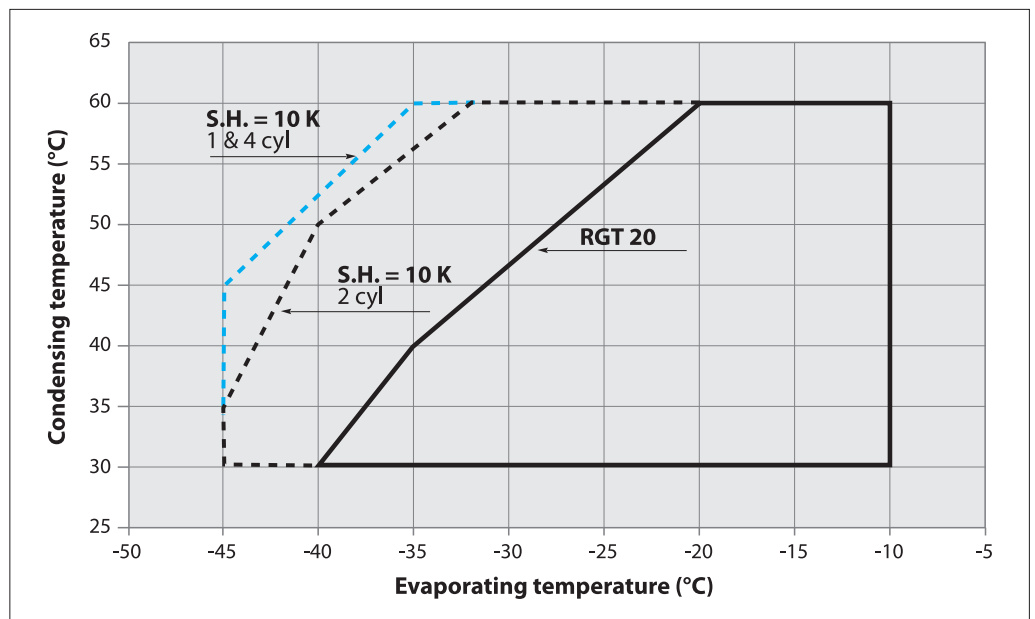

Discharge temperature protection

Even when the motor windings are protected against overheating by the internal motor protection, the compressor discharge gas temperature could exceed the maximum allowed value of 135°C when the compressor is operated outside its application envelope. The most effective protection against too high discharge gas temperature is to mount a discharge gas thermostat. An accessory kit is available from Danfoss which includes the thermostat, mounting bracket and insulation. The thermostat must be attached to the

discharge line as indicated below at no more than 150 mm from the discharge connection.

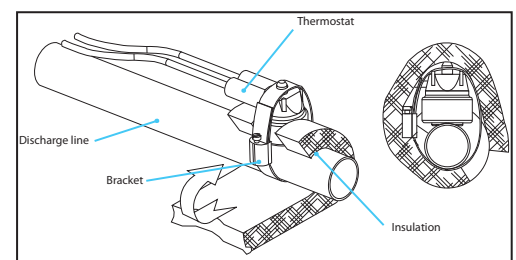

Operating limits

High pressure

A high-pressure (HP) safety switch is required to shut down the compressor should the discharge pressure exceed the values shown in the table below. This switch can be set at lower values depending on the application and ambient conditions. It must be either located in a lockout circuit or

associated with a manual reset device to prevent cycling around the high pressure limit.

If a discharge valve is used, the HP switch must be connected to the service valve gauge port, which cannot be isolated.

Low pressure

A low-pressure (LP) safety switch must also be used; deep vacuum operations will result in failure. The minimum LP safety switch (loss of charge switch) setting is 0 relative bar (0 bar g). For systems without pump-down feature, the LP safety switch must be either a manual lockout device or

an automatic LP safety switch wired into an electrical lockout circuit. LP switch tolerance must not allow for vacuum operation of the compressor. LP safety switch settings for pump-down cycles with automatic reset are listed in the following table.

		NTZ – R404A / R507
Working pressure range, high side	(bar gauge)	13.2 – 27.7
Working pressure range, low side	(bar gauge)	0.1 – 3.3
Minimum low pressure safety switch setting	(bar gauge)	0
Minimum low pressure pump-down switch setting	(bar gauge)	0.21
Relief valve opening pressure difference	(bar)	30
Relief valve closing pressure difference	(bar)	8

Maneurop® NTZ compressors have been designed and qualified for stationary equipment using standard alternating power supply. Danfoss does not warrant the compressors for use on mobile applications such as trucks, railways, subways, ships etc.

These selection and application guidelines concern single compressors only. For guidelines on manifolding Maneurop® NTZ compressors, please refer to literature called "Parallel Application Guidelines".

Piping design

Oil in a refrigeration circuit is required to lubricate moving parts in the compressor. During normal system operation small oil quantities will continuously leave the compressor, with the discharge gas. Therefore, the system piping shall be designed in a way which allows a good oil circulation, avoiding oil being trapped in the system and ensuring a constant oil return to the compressor. As long as the amount of oil circulating through the system is small it will contribute to good system operation and improved heat transfer efficiency.

Lubricant getting trapped in the evaporator or suction lines will affect system performance and will ultimately lead to compressor lubrication failures. Where a poor oil return situation exists, adding lubricant will not help safeguard the compressor. Only a correct piping design can ensure adequate oil circulation maintaining safe oil level in the compressor.

Suction line

Horizontal suction line sections shall have a slope of 0.5% in the direction of refrigerant flow (5 mm per meter). The cross-section of horizontal suction lines shall be such that the resulting gas velocity is at least 4 m/s. In vertical risers, a gas velocity of 8 to 12 m/s is required to ensure proper oil return.

A U-trap is required at the foot of each vertical riser. If the riser is higher than 4 m, additional U-traps are required for each additional 4 meters. The length of each U-trap must be as short as possible to avoid the accumulation of excessive quantities of oil (see figure below).

Gas velocities higher than 12 m/s will not contribute to significantly better oil return. However they will cause higher noise levels and result in higher suction line pressure drops which will have a negative effect on the system capacity. Note that the suction rotolock valves, which can be ordered from Danfoss as accessories, are designed for average pipe sizes, selected for systems running at nominal conditions. The pipe sizes selected for specific systems may differ from these average sizes.

The suction line must always be insulated to limit suction gas superheat.

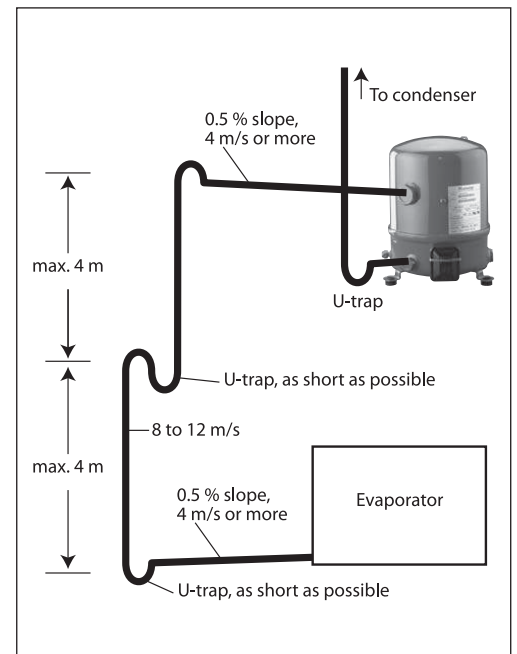

Discharge line

When the condenser is mounted above the compressor, a loop above the condenser and a U-trap close to the compressor are required to prevent liquid draining from the condenser into the discharge line during standstill.

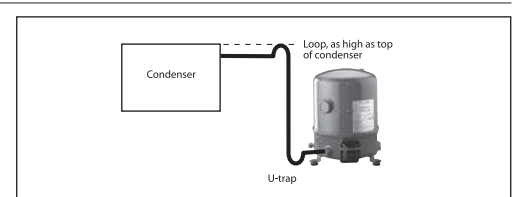

Oil charge and oil separator

In most installations the initial compressor oil charge will be sufficient. In installations with line runs exceeding 20 m, or with many oil traps or an oil separator, additional oil may be required. In

installations with the risk of slow oil return such as in multiple evaporator or multiple condenser installations, an oil separator is recommended. Also refer to the section "Oil charge and oil level".

Filter driers

For new installations with NTZ compressors Danfoss recommends using the Danfoss DML 100% molecular sieve, solid core filter drier. Molecular sieve filter driers with loose beads from third party suppliers shall be avoided.

filter driers containing activated alumina are recommended.

For servicing of existing installations where acid formation is present the Danfoss DCL solid core

The drier is to be oversized rather than undersized. When selecting a drier, always take into account its capacity (water content capacity), the system refrigerating capacity and the system refrigerant charge.

Suction pressure control

An MOP-type expansion valve or suction pressure regulator (i.e. Danfoss KVL) must be used to limit suction pressure at a maximum of 4 bar relative (-5°C). Do not apply both of these devices in combination with one another.

When compressors are mounted onto a rack for a multi-evaporator system (i.e. supermarket) or when evaporators operate at different temperatures, use pressure regulators (Danfoss KVP) without an MOP expansion valve.

Suction line heat exchanger

A suction line heat exchanger is recommended for low temperature applications, better performance and efficiency are expected. However

in hot location this may cause high suction gas superheat which can result in too high discharge temperature.

Low ambient temperature operation

At low ambient temperatures, the condensing temperature and condensing pressure in air cooled condensers will decrease. This low pressure may be insufficient to supply enough liquid refrigerant to the evaporator. As a result the evaporating temperature will decrease, leading to low capacity and eventual poor oil return. At start-up, the compressor will pull into vacuum and it will be switched off by the low pressure protection. Depending on how the low pressure switch and delay timer are set, short cycling can occur. To avoid these problems, several solutions are possible, based on reducing condenser capacity:

The minimum condensing pressure must be set at the minimum saturated condensing temperature shown in the application envelopes.

In air-cooled machines, cycling the fans with a head pressure controller will ensure that the fans remain off until the condensing pressure has reached a satisfactory level. Variable speed fans can also be used to control the condensing pressure. In water-cooled units, the same can be performed using a water regulator valve that is also operated by head pressure, thereby ensuring that the water valve does not open until the condensing pressure reaches a satisfactory level.

Under very low ambient conditions, in which testing has revealed that the above procedures might not ensure satisfactory condensing and suction pressures, the use of a head pressure control valve is recommended. Note: This solution requires extra refrigerant charge, which can introduce other problems. A non-return valve in the discharge line is recommended and special care should be taken when designing the discharge line.

When the compressor is located in a low ambient temperature environment, increased refrigerant migration will occur during shut down periods. For such conditions an extra belt-type crankcase heater is strongly recommended.

Note that with 100% suction gas cooled motors, Maneurop® compressors can be externally insulated. Refer to section "Liquid refrigerant migration & charge limits" for more details.

Cycle rate limit

No more than 12 starts per hour (6 when a soft start accessory is used) are allowed. A higher number would reduce the service life of the motor-compressor unit. If necessary, use an anti-short-cycle timer within the control circuit.

The system must be designed in a way that guarantees minimum compressor running time so as to provide sufficient motor cooling after start-up

as well as proper oil return from the system to the compressor.

A 5-minute delay between two successive compressor starts is being proposed herein, with a 2-minute runtime after each start and a 3-minute idle time between each stop and start.

Only during the pump-down cycle may the compressor run for much shorter intervals.

Liquid refrigerant control and charge limits

Refrigeration compressors are basically designed as gas compressors. Depending on the compressor design and operating conditions, most compressors can also handle a limited amount of liquid refrigerant. Maneurop® NTZ compressors have a large internal volume and can therefore handle relatively large amounts of liquid refrigerant without major problems.

However even when a compressor can handle liquid refrigerant, this will not be favourable to its service life.

Liquid refrigerant will dilute the oil, wash out the bearings causing wear and eventually seizure. Furthermore, high oil carry over will cause lack of oil in the sump.

Good system design can limit the amount of liquid refrigerant in the compressor, which will have a positive effect on the compressor service life.

Liquid refrigerant can enter a compressor in various ways, with different effects on the compressor as described in the following points.

Off-cycle migration

During system standstill and after pressure equalisation, refrigerant will condensate in the coldest part of the system which may be the compressor when it is placed in a cold environment. Ultimately, the full system refrigerant charge can condensate in the compressor crankcase. A large amount will dissolve in the compressor oil until the oil is completely saturated with refrigerant. When the

compressor is started, the pressure in the crankcase decreases rapidly and refrigerant will violently evaporate, causing the oil to foam (boiling). Both dilution and foaming reduce the lubrication properties of the oil. In extreme situations liquid could enter the compressor cylinders with immediate compressor break-down as a result.

Liquid floodback during operation

During normal and stable system operation, refrigerant will leave the evaporator in a superheated condition and enter the compressor as a superheated vapour. Normal superheat values at compressor suction are 5 to 30 K. However the refrigerant leaving the evaporator can contain an amount of liquid refrigerant due to different reasons:

- wrong dimensioning, wrong setting or malfunction of expansion device

- evaporator fan failure or frosted-up evaporator coils.

In these situations, liquid refrigerant will continuously enter the compressor. The negative effects from continuous liquid floodback are:

- permanent oil dilution
- in extreme situations with high system refrigerant charge and large amounts of floodback, liquid slugging could occur.

Crankcase heater

A crankcase heater protects against the off-cycle migration of refrigerant and proves effective if oil temperature is maintained 10 K above the saturated LP temperature of the refrigerant. Tests must thereby be conducted to ensure that the appropriate oil temperature is maintained under all ambient conditions. A PTC crankcase heater is required with all Maneurop[®], NTZ compressors. PTC crankcase heaters are self-regulating.

Under extreme conditions such as low ambient temperature at -15°C or lower a belt type crankcase heater could be used in addition to the PTC heater, although this is not a preferred solution for 1 and 2 cylinder compressors. The belt crankcase heater must be positioned on the compressor shell as close as possible to the oil sump to ensure good heat transfer to the oil. The below illustrated mounting positions are recommended:

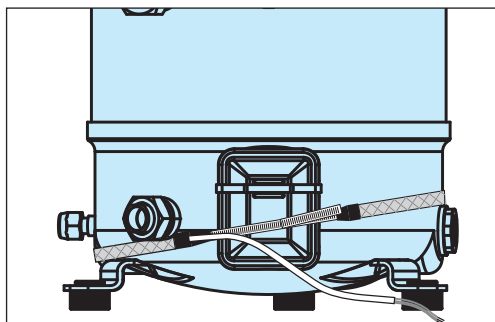

Models: NTZ048 - NTZ068 - NTZ096 - NTZ108 - NTZ136

Belt crankcase heaters are not self-regulating. Control must be applied to energise the belt heater once the compressor has been stopped and then to de-energise it while the compressor is running. The belt heater must be energised 12 hours before restarting the compressor following an extended down period.

If the crankcase heater is not able to maintain the oil temperature at 10 K above the saturated LP temperature of the refrigerant during off cycles or if repetitive floodback is present a the Liquid Line Solenoid Valve (LLSV) + pump-down cycle is required, possibly in conjunction with a suction accumulator.

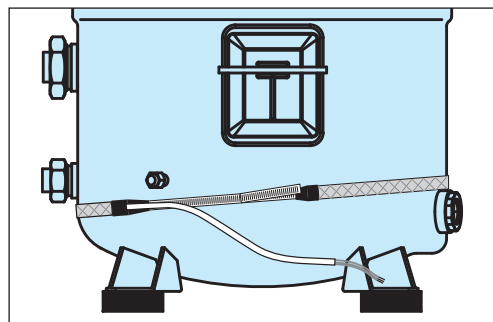

Models: NTZ215 - NTZ271

Liquid line solenoid valve & pump-down

In refrigeration applications, the Liquid Line Solenoid Valve (LLSV) is highly recommended. During the off-cycle, the LLSV isolates the liquid charge in the condenser side, thus preventing refrigerant transfer or excessive migration of refrigerant into the compressor. Furthermore, when using LLSV in conjunction with the pump-down cycle

(especially in low-temperature applications), the quantity of refrigerant in the low-pressure side of the system will be reduced.

A pump-down cycle design is required when evaporators are fitted with electric defrost heaters.

Suction accumulator

A suction accumulator offers considerable protection against refrigerant floodback both at start-up and during operation or after the defrost operation. This device also helps protect against off-cycle migration by providing additional internal free volume to the low pressure side of the system.

The suction accumulator must be selected in accordance with the accumulator manufacturer recommendations. As a general rule, Danfoss Commercial Compressors recommends to size the accumulator for at least 50% of the total system charge. Tests however must be conducted to determine the optimal size.

Sound

Compressors in operation are one of the sources of sound and vibration in a refrigeration system. Both phenomena are closely related.

Sound produced by a compressor is transmitted in every direction by the ambient air, the mounting feet, the pipework and the refrigerant in the pipework. The easiest way to reduce the sound transmitted through ambient air is to fit an acous-

tic hood accessory. Because Maneurop® NTZ compressors are 100% suction gas cooled and require no external cooling they can be insulated or enclosed in a sound proofing material lined compartment.

Sound transmitted by mounting feet, pipework and refrigerant should be treated the same way as vibration (see next section).

Compressor model	Sound power level* at 50 hz dB(A)		Sound power level* at 60 Hz dB(A)		Acoustic hood code no.
	without hood	with hood	without hood	with hood	
NTZ048	72	65	75	68	7755001
NTZ068	70	64	74	68	
NTZ096	82	74	85	77	7755002
NTZ108	76	69	80	75	
NTZ136	77	71	80	75	
NTZ215	86	80	88	81	7755003
NTZ271	86	80	88	81	

(*) Operating conditions: R404A, Evap. temp.: -35°C, Cond. temp.: 40°C, 400 V / 50Hz

Vibration

The mounting grommets delivered with the compressor should always be used. They will largely attenuate the compressor vibration transmitted to the base frame. These rubber grommets have been selected and calculated in accordance with the vibration frequencies that are typical for the compressor. For that reason other grommet types or brands shall not be used.

The base on which the compressor is mounted should be sufficiently rigid and of adequate mass to ensure the full effectiveness of the mounting

grommets. The compressor should never be rigidly mounted to the base frame otherwise high vibration transmission would occur and the service life reduced. Suction and discharge lines must have adequate flexibility in 3 planes. Eventually vibration absorbers may be required.

Vibration is also transmitted by the refrigerant gas. Maneurop® NTZ compressors have built-in mufflers to reduce pulsation. To further reduce vibration an extra discharge line muffler can be installed.

System cleanliness

System contamination is one of the main factors that affects equipment reliability and compressor service life. Therefore it is important to take care of the system cleanliness when assembling a refrigeration system. During the manufacturing process, circuit contamination can be caused by:

- Brazing and welding oxides,
- Filings and particles from removing burrs from pipe-work,
- Brazing flux,
- Moisture and air.

Only use clean and dehydrated, refrigeration-grade copper tubes and silver alloy brazing material. Clean all parts before brazing and always

purge nitrogen or CO₂ through the pipes during brazing to prevent oxidation. If flux is used, take every precaution to prevent the leakage of flux into the piping. The use of flux core or flux coated braze wire or rod instead of brush applied paste flux is strongly recommended. Do not drill holes (e.g. for schrader valves) in parts of the installation that are already completed, when filings and burrs cannot be removed. Carefully follow the instructions below regarding brazing, mounting, leak detection, pressure test and moisture removal. All installation and service work shall only be done by qualified personnel respecting all procedures and using tools (charging systems, tubes, vacuum pumps, etc.) dedicated for R404A and R507.

Compressor handling, mounting and connection

Compressor handling

Maneurop® NTZ compressors must be handled with care and all handling procedures must be performed smoothly and gently. Each NTZ has been fitted with one lift ring which shall always be used to lift the compressor. Once the compressor is installed, the lift ring shall never be used to lift the complete installation.

Always use the proper tools for transporting the compressor. Keep the compressor in an upright position during all handling tasks (manipulating, transport, storage). The angle off the vertical must not exceed 15 degrees.

Compressor mounting

The compressor must be mounted onto a horizontal surface with a maximum slope of 3 degrees. Always use the rubber mounting grommets that

are shipped with the compressor. Mounting torques are listed in the below table.

Component	Torque (Nm)	
	Min.	Max.
Rotolock suction valve, NTZ048 - NTZ068	80	100
Rotolock suction valve, NTZ096 - NTZ271	100	120
Rotolock discharge valve, NTZ048 – NTZ068	70	90
Rotolock discharge valve, NTZ096 - NTZ271	80	100
Electrical T-block screws HN°10-32 UNF x 9.5	-	3
Earth screw	-	3
Oil sight glass (with black chloroprene gasket)	40	45
3/8" flare oil equalisation nut	45	50
Schrader nut	11.3	17
Schrader valve (internal)	0.4	0.8
Mounting grommet bolt, NTZ048 – NTZ136	12	18
Mounting grommet bolt, NTZ215 - NTZ271	40	60
Belt crankcase heater	-	4

Compressor connection to the system

New compressors have a protective nitrogen holding charge. Only remove the suction and discharge plugs just before connecting the compressor to the installation, so as to prevent air and moisture from entering the compressor. Remove the discharge plug first and the suction plug next; by proceeding as such, the nitrogen holding charge can escape via the discharge connection and the risk of an oil mist blow-out via the suction connection will be minimal.

Whenever possible the compressor must be the last component to be integrated in the system. It is advisable to braze the solder sleeves or service valves to the pipework before the compressor is mounted. When all brazing is finished and when the total system is ready, the compressor plugs can be removed and the compressor can be mounted to the system with a minimum exposure to ambient air. If this procedure is not possible, the sleeves or valves may be brazed to the

pipes when mounted on the compressor. In this situation nitrogen or CO₂ must be purged through the compressor via the schrader valve to prevent air and moisture ingress. Purging must start when the plugs are removed and maintained during the brazing process.

When rotolock valves are used on the compressor, they shall be closed immediately after mounting, thus keeping the compressor isolated from atmosphere or from a not yet dehydrated system.

Note: when the compressor is built into a "pack" or "rack" configuration which is not installed immediately on its final location, a vacuum pull-down and moisture removal must be performed to the "pack" or "rack" as if it were a complete system (see below). The pack must be charged with nitrogen or CO₂ and open tubes must be blocked with caps or plugs.

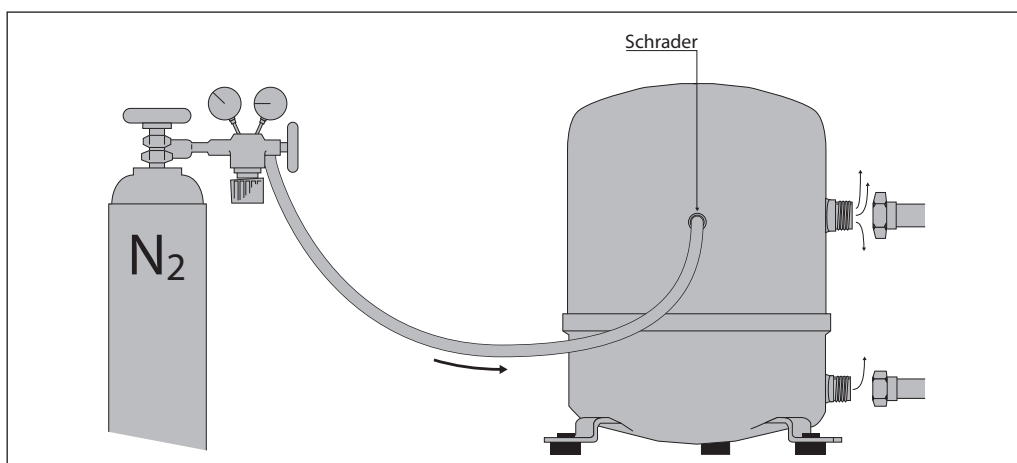

System pressure test

Always use an inert gas such as nitrogen for the pressure test. Never use other gasses such as oxygen, dry air or acetylene. These gasses may form an inflammable mixture with the compressor oil. Always use the appropriate pressure regulator with gas cylinders. Any attempt to use a high

pressure gas supply without a suitable pressure regulator can lead to personal injury or death as well as system damage.

The maximum allowed test pressures for NTZ compressors are:

Maximum compressor test pressure at low pressure side (suction side)	25 bar (g)
Maximum compressor test pressure at high pressure side (discharge side)	30 bar (g)
Maximum test pressure difference between high and low pressure side (to avoid that the internal compressor relief valve will open)	30 bar

Leak detection

Whenever possible the compressor must be kept isolated from the system during leak detection by closing the suction and discharge valves. Use a mixture of nitrogen and the final refrigerant (eg. R404A or R507) and use a leak detector for the applied refrigerant. A spectrometric detection system using helium can also be applied. Note that leak detection with refrigerant may not be allowed in some countries. Do not use other gasses such as oxygen, dry air or acetylene as these

gasses can form an inflammable mixture with the compressor oil. Never use CFC or HCFC refrigerants for leak detection of HFC systems. Leak detecting additives shall not be used as they may affect the lubricant properties. Warranty may be voided if leak detection additives have been used.

Eventual leaks shall be repaired respecting the instructions written above.

Vacuum pump-down and dehydration procedure

Moisture obstructs proper operation of the compressor and the rest of the refrigeration system. Air and moisture reduce service life, increase condensing pressure and cause excessively high discharge temperatures, which are capable of destroying the lubricating properties of the oil. Air and moisture also increase the risk of acid formation, thus giving rise to copper plating. All these phenomena can ultimately induce mechanical and electrical compressor failure. To eliminate these risks, it is recommended to perform the following vacuum pull-down procedure:

1. To the extent possible (i.e. if valves are present), the compressor must be kept isolated from the system.
2. After leak detection, the system must be pulled-down under a vacuum of 500 microns (0.67 mbar). A two-stage vacuum pump shall be used with a capacity appropriate for the system volume. It is recommended to use connection lines with a large diameter and to connect these lines to the service valves and not to the schrader connection, so as to avoid excessive pressure losses.
3. Once the vacuum level of 500 microns is reached, the system must be isolated from the vacuum pump. Wait 30 minutes during which

time the system pressure should not rise. When the pressure rapidly increases, the system is not leak tight. Bring the system pressure up to atmospheric pressure with dry nitrogen or another suitable inert gas in order to reform a new leak detection. After repairing all leaks the vacuum pull-down procedure should be restarted from Step 1. When the pressure slowly increases, this indicates the presence of moisture. In this case Steps 2 and 3 should be repeated.

4. Connect the compressor to the system by means of opening the valves. Repeat Steps 2 & 3.
5. Break the vacuum with either nitrogen or the ultimate refrigerant.
6. Repeat Steps 2 and 3 on the total system.

Upon commissioning, the system moisture content may be as high as 100 ppm. During compressor operation, the filter drier must reduce this content to a level of 20 to 50 ppm.

Warning: do not use a megohmmeter or apply power to the compressor while it is under vacuum as this may cause motor winding damage, and never run the compressor under vacuum as this may cause the compressor motor to burnout.

Start-up

Before initial start-up or after a prolonged shut-down period, energise the crankcase heater 12 hours prior to start-up. If the crankcase heater cannot be energised long enough before start-up, the compressor shall be heated in another

way (for example with an electric heater or flood light) to boil off refrigerant from the oil. This is particularly important when ambient temperature is low at commissioning.

Refrigerant charging

It is recommended that charging be done to the high side of the system. Charge refrigerant as close as possible to the nominal system charge before starting the compressor. Then slowly add refrigerant on the low pressure side as far away as possible from the compressor suction connection. The refrigerant charge quantity must be suitable for both winter and summer operation.

R404A is a near-azeotropic mixture and must be charged in the liquid phase. R507 is an azeotropic mixture and can be charged either in liquid or gas phase.

Warning: when a liquid line solenoid valve is used, the vacuum in the low pressure side must be broken before applying power to the system.

Oil charge and oil level

The oil charge must be checked before commissioning (1/4 to 3/4 of the oil sight glass). Watch the oil level at start and for the first 15 minutes after start. Check the oil level again after a minimum of 2 hours operation at nominal conditions. In most installations the initial compressor oil charge will be sufficient. In installations with line runs exceeding 20 m or with many oil traps or an oil separator, additional oil may be required. Normally the quantity of oil added should be no more than 2% of the total refrigerant charge. This per-

centage does not take into account oil contained in accessories such as oil separators or oil traps. If this amount has already been added and the oil level in the compressor keeps decreasing, the oil return in the installation is insufficient. Refer to section "Piping design". In installations where slow oil return is likely such as in multiple evaporator or multiple condenser installations an oil separator is recommended. Always use Danfoss 160Z lubricant for systems with NTZ compressors and R404A or R507.

Installation checks

After a few running hours the main system parameters shall be verified to ensure that the system is working correctly or eventually to adjust the settings.

setting is correct, the suction line insulation between evaporator and compressor should be checked and eventually replaced by a higher quality insulation.

- The evaporating temperature and condensing temperature shall be compared with the design conditions.
- The superheat at the evaporator outlet must be adjusted to optimise the evaporator performance. Generally a value of 5 to 6 K is recommended.
- The compressor suction temperature gives information about the suction gas superheat at the compressor. NTZ compressors can be operated at a maximum suction gas temperature of 20°C. Note that extremely low superheat values can increase the risk of unwanted liquid floodback to the compressor. When a too high superheat is noted while the expansion valve

- A too high discharge gas temperature can indicate a malfunctioning condenser, too high suction gas superheat. Measurements through a probe sensor pushed against the discharge tube are not accurate. From 115°C, we recommend to use a thermocouple, brazed and insulated on the discharge tube, 10 cm far from the compressor body. The maximum allowed discharge temperature is 135°C.
- Power and current consumption shall be compared with the table values at measured evaporating and condensing temperature.
- When after commissioning the liquid sight glass indicates moisture, the filter drier must immediately be replaced.

**Code numbers
(for ordering)**
NTZ compressors in single pack*

Compressor model	Motor voltage code				
	1	3	4	5	9
	208-230/1/60	200-230/3/60	460/3/60 400/3/50	230/1/50	380/3/60
NTZ048	120F0072	120F0026	120F0001	120F0087	120F0168
NTZ068	120F0073	120F0027	120F0002	120F0088	120F0169
NTZ096	120F0074	120F0028	120F0003		
NTZ108	120F0075	120F0029	120F0004		120F0170
NTZ136	120F0076	120F0030	120F0005		120F0171
NTZ215		120F0031	120F0006		120F0172
NTZ271		120F0032	120F0007		120F0173
NTZ430 *			120F0024		
NTZ542 *			120F0025		

* tandem units

NTZ compressors in industrial pack***

Compressor model	Motor voltage code				
	1	3	4	5	9
	208-230/1/60	200-230/3/60	460/3/60 400/3/50	230/1/50	380/3/60
NTZ048	120F0077	120F0033	120F0008	120F0089	120F0174
NTZ068	120F0078	120F0034	120F0009	120F0090	120F0175
NTZ096	120F0079	120F0035	120F0010		
NTZ108	120F0080	120F0036	120F0011		120F0176
NTZ136	120F0081	120F0037	120F0012		120F0177
NTZ215		120F0038	120F0013		120F0178
NTZ271		120F0039	120F0014		120F0179

Packaging

Compressor model	Single pack*		Multi pack **				Industrial pack***			
	Weight (kg)	Dimensions (mm)	Qty	Weight (kg)	Dimensions (mm)	Static stacking	Qty	Weight (kg)	Dimensions (mm)	Static stacking
NTZ048	23	l: 385 w: 285 h: 370	8	197	l: 1150 w: 800 h: 510		12	278	l: 1150 w: 800 h: 500	
NTZ068	25			213				302		
NTZ096	38	l: 385 w: 375 h: 450	6	238	l: 1150 w: 800 h: 600	4	6	230	l: 1150 w: 800 h: 600	4
NTZ108	38			238				230		
NTZ136	38			238				230		
NTZ215	72			l: 570 w: 400 h: 670				4		
NTZ271	73	303	399							

* Single pack: one compressor packed in a cardboard box 4 cyl.: cardboard box on 1/4 euro pallet

** Multi pack: a pallet filled with single-packs

*** Industrial pack: a full pallet of unpacked compressors

Rotolock service valves and valve sets (without gasket)

Type	Code n°	Description	Application	Packaging	Pack size
V01	8168027	Rotolock valve, V01 (1" Rotolock, 3/8" ODF)	Models with 1" rotolock connection	Multipack	6
V01	7968003	Rotolock valve, V01 (1" Rotolock, 3/8" ODF)		Industry pack	50
V06	8168031	Rotolock valve, V06 (1" Rotolock, 1/2" ODF)	Models with 1" rotolock connection	Multipack	6
V06	7968004	Rotolock valve, V06 (1" Rotolock, 1/2" ODF)		Industry pack	50
V04	8168029	Rotolock valve, V04 (1"1/4 Rotolock, 3/4" ODF)	Models with 1"1/4 rotolock connection	Multipack	6
V04	7968006	Rotolock valve, V04 (1"1/4 Rotolock, 3/4" ODF)		Industry pack	42
V05	8168030	Rotolock valve, V05 (1"1/4 Rotolock, 7/8" ODF)	Models with 1"1/4 rotolock connection	Multipack	6
V05	7968007	Rotolock valve, V05 (1"1/4 Rotolock, 7/8" ODF)		Industry pack	36
V09	8168033	Rotolock valve, V09 (1"1/4 Rotolock, 5/8" ODF)	Models with 1"1/4 rotolock connection	Multipack	6
V09	7968005	Rotolock valve, V09 (1"1/4 Rotolock, 5/8" ODF)		Industry pack	50
V02	8168028	Rotolock valve, V02 (1"3/4 Rotolock, 1"1/8 ODF)	Models with 1"3/4 rotolock connection	Multipack	6
V02	7968009	Rotolock valve, V02 (1"3/4 Rotolock, 1"1/8 ODF)		Industry pack	24
V07	8168032	Rotolock valve, V07 (1"3/4 Rotolock, 7/8" ODF)	Models with 1"3/4 rotolock connection	Multipack	6
V07	7968008	Rotolock valve, V07 (1"3/4 Rotolock, 7/8" ODF)		Industry pack	36
V10	8168022	Rotolock valve, V10 (1"3/4 Rotolock, 1-3/8" ODF)	Models with 1"3/4 rotolock connection	Single pack	1
V09, V06	7703005	Valve set, V09 (1"1/4~5/8"), V06 (1"~1/2")	NTZ048-068	Multipack	4
V07, V04	7703006	Valve set, V07 (1"3/4~7/8"), V04 (1"1/4~3/4")	NTZ096-108	Multipack	6
V02, V04	7703009	Valve set, V02 (1"3/4~1"1/8), V04 (1"1/4~3/4")	NTZ136-271	Multipack	6

Rotolock angle adapters and sets

Type	Code n°	Description	Application	Packaging	Pack size
C01	8168004	Angle adapter, C01 (1" Rotolock, 3/8" ODF)	Models with 1" rotolock connection	Multipack	6
C06	8168007	Angle adapter, C06 (1" Rotolock, 1/2" ODF)		Multipack	6
C04	8168006	Angle adapter, C04 (1"1/4 Rotolock, 3/4" ODF)	Models with 1"1/4 rotolock connection	Multipack	6
C09	8168009	Angle adapter, C09 (1"1/4 Rotolock, 5/8" ODF)		Multipack	6
C02	8168005	Angle adapter, C02 (1"3/4 Rotolock, 1"1/8 ODF)	Models with 1"3/4 rotolock connection	Multipack	6
C07	8168008	Angle adapter, C07 (1"3/4 Rotolock, 7/8" ODF)		Multipack	6
C09, C06	7703012	Angle adapter set, C09 (1"1/4~5/8"), C06 (1"~1/2")	NTZ048-068	Multipack	4
C07, C04	7703013	Angle adapter set, C07 (1"3/4~7/8"), C04 (1"1/4~3/4")	NTZ096-108	Multipack	6
C02, C04	7703014	Angle adapter set, C02 (1"3/4~1"1/8), C04 (1"1/4~3/4")	NTZ136-271	Multipack	6

Rotolock nuts

Type	Code n°	Description	Application	Packaging	Pack size
	8153122	Rotolock nut, 1"	Models with 1" rotolock connection	Multipack	10
	7953001	Rotolock nut, 1"		Industry pack	50
	8153123	Rotolock nut, 1"1/4	Models with 1"1/4 rotolock connection	Multipack	10
	7953002	Rotolock nut, 1"1/4		Industry pack	50
	8153124	Rotolock nut, 1"3/4	Models with 1"3/4 rotolock connection	Multipack	10
	7953003	Rotolock nut, 1"3/4		Industry pack	50

Solder sleeves

Type	Code n°	Description	Application	Packaging	Pack size
P01	8153010	Solder sleeve, P01 (1" Rotolock, 3/8" ODF)	Models with 1" rotolock connection	Multipack	10
P01	7953004	Solder sleeve, P01 (1" Rotolock, 3/8" ODF)		Industry pack	50
P06	8153007	Solder sleeve, P06 (1" Rotolock, 1/2" ODF)	Models with 1" rotolock connection	Multipack	10
P06	7953009	Solder sleeve, P06 (1" Rotolock, 1/2" ODF)		Industry pack	50
P09	8153011	Solder sleeve, P09 (1"1/4 Rotolock, 5/8" ODF)	Models with 1"1/4 rotolock connection	Multipack	10
P09	7953011	Solder sleeve, P09 (1"1/4 Rotolock, 5/8" ODF)		Industry pack	50
P04	8153008	Solder sleeve, P04 (1"1/4 Rotolock, 3/4" ODF)	Models with 1"1/4 rotolock connection	Multipack	10
P04	7953007	Solder sleeve, P04 (1"1/4 Rotolock, 3/4" ODF)		Industry pack	50
P05	8153012	Rotolock connector, P05 (1"1/4 Rotolock, 7/8" ODS)	Models with 1"1/4 rotolock connection	Multipack	10
P05	7953008	Rotolock connector, P05 (1"1/4 Rotolock, 7/8" ODS)		Industry pack	50
P07	8153013	Solder sleeve, P07 (1"3/4 Rotolock, 7/8" ODF)	Models with 1"3/4 rotolock connection	Multipack	10
P07	7953010	Solder sleeve, P07 (1"3/4 Rotolock, 7/8" ODF)		Industry pack	50
P02	8153004	Solder sleeve, P02 (1"3/4 Rotolock, 1"1/8 ODF)	Models with 1"3/4 rotolock connection	Multipack	10
P02	7953005	Solder sleeve, P02 (1"3/4 Rotolock, 1"1/8 ODF)		Industry pack	50
P10	8153003	Solder sleeve, P10	Models with 1"3/4 rotolock connection	Multipack	10

Gaskets and gasket set

Type	Code n°	Description	Application	Packaging	Pack size
G01	8156130	Gasket, 1"	Models with 1" rotolock connection	Multipack	10
G01	7956001	Gasket, 1"		Industry pack	50
G09	8156131	Gasket, 1"1/4	Models with 1"1/4 rotolock connection	Multipack	10
G09	7956002	Gasket, 1"1/4		Industry pack	50
G07	8156132	Gasket, 1"3/4	Models with 1"3/4 rotolock connection	Multipack	10
G07	7956003	Gasket, 1"3/4		Industry pack	50
	8156009	Gasket set, 1", 1"1/4, 1"3/4, OSG gaskets black & white	All 1-2-4 cylinder models	Multipack	10

Belt heaters

Type	Code n°	Description	Application	Packaging	Pack size
	7773106	Belt type crankcase heater, 54 W, 230 V, CE mark, UL	NTZ048-068	Multipack	4
	7773013	Belt type crankcase heater, 54 W, 400 V, UL		Multipack	4
	7773109	Belt type crankcase heater, 65 W, 110 V, CE mark, UL	NTZ096-108-136	Multipack	6
	7973001	Belt type crankcase heater, 65 W, 110 V, CE mark, UL		Industry pack	50
	7773107	Belt type crankcase heater, 65 W, 230 V, CE mark, UL		Multipack	6
	7973002	Belt type crankcase heater, 65 W, 230 V, CE mark, UL		Industry pack	50
	7773117	Belt type crankcase heater, 65 W, 400 V, CE mark, UL		Multipack	6
	120Z0466	Belt type crankcase heater, 65 W, 460 V, CE mark, UL		Multipack	6
	120Z0467	Belt type crankcase heater, 65 W, 575 V, CE mark, UL	Multipack	6	
	7773110	Belt type crankcase heater, 75 W, 110 V, CE mark, UL	NTZ215-271	Multipack	6
	7773108	Belt type crankcase heater, 75 W, 230 V, CE mark, UL		Multipack	6
	7973005	Belt type crankcase heater, 75 W, 230 V, CE mark, UL		Industry pack	50
	7773118	Belt type crankcase heater, 75 W, 400 V, CE mark, UL		Multipack	6
	120Z0464	Belt type crankcase heater, 75 W, 460 V, CE mark, UL		Multipack	6
	120Z0465	Belt type crankcase heater, 75 W, 575 V, CE mark, UL		Multipack	6

PTC heaters

Type	Code n°	Description	Application	Packaging	Pack size
PTC27W	120Z0459	PTC heater 27W	All models	Multipack	10
PTC27W	120Z0460	PTC heater 27W	All models	Industry pack	50

Single phase PSC starting kits

Type	Code n°	Description	Application	Packaging	Pack size
PSC	7701025	Permanent capacitors 440V, 15 µF, 10 µF	NTZ 048-1	Multipack	4
PSC	7701026	Permanent capacitors 440V, 20 µF, 10 µF	NTZ 048-5, 068-5	Multipack	4
PSC	7701035	Permanent capacitors 440V, 30 µF, 15 µF	NTZ096-1, 108-1, 136-1	Multipack	4
PSC	7701151	Permanent capacitors 440V, 25 µF, 25 µF	NTZ 068-1	Multipack	4

Single phase CSR starting kits

Type	Code n°	Description	Application	Packaging	Pack size
CSR	7701021	Relay + Capacitors : run (15 + 10 µF), start (98 µF)	NTZ 048-1	Multipack	4
CSR	7701022	Relay + Capacitors : run (20 + 10 µF), start (98 µF)	NTZ 048-5, 068-5	Multipack	4
CSR	7701154	Relay + Capacitors : run (25 + 25 µF), start (140 µF)	NTZ 068-1	Multipack	4
CSR	7701042	Relay + Capacitors : run (30 + 15 µF), start (140 µF)	NTZ096-1, 108-1, 136-1	Multipack	6

Single phase CSR starting kits, prewired box

Type	Code n°	Description	Application	Packaging	Pack size
	7701028	Relay + Capacitors : run (20 + 10 µF), start (98 µF)	NTZ 048-5, 068-5	Single pack	1
	7701148	Relay + Capacitors : run (25 + 25 µF), start (140 µF)	NTZ 068-1	Single pack	1
	7701049	Relay + Capacitors : run (30 + 15 µF), start (140 µF)	NTZ096-1, 108-1, 136-1	Single pack	1

Relays and capacitors

Type	Code n°	Description	Application	Packaging	Pack size
	8173022	Starting relay type RVA6AMKL	All Single pack phase models (code 1 & 5)	Single pack	1
	8173037	Run capacitor 440V,10 µF	PSC & CSR starting kits	Multipack	10
	8173038	Run capacitor 440V,15 µF	PSC & CSR starting kits	Multipack	10
	8173039	Run capacitor 440V,20 µF	PSC & CSR starting kits	Multipack	10
	8173040	Run capacitor 440V,25 µF	PSC & CSR starting kits	Multipack	10
	8173041	Run capacitor 440V,30 µF	PSC & CSR starting kits	Multipack	10
	8173042	Run capacitor 440V,35 µF	PSC & CSR starting kits	Multipack	10
	8173231	Run capacitor 440V,40 µF	PSC & CSR starting kits	Multipack	10
	8173232	Run capacitor 440V,45 µF	PSC & CSR starting kits	Multipack	10
	8173233	Run capacitor 440V,50 µF	PSC & CSR starting kits	Multipack	10
	8173234	Run capacitor 440V,55 µF	PSC & CSR starting kits	Multipack	10
	8173001	Start capacitor 330V, 98 µF	CSR starting kits	Multipack	10
	8173002	Start capacitor 330V, 140 µF	CSR starting kits	Multipack	10

Motor protection modules and transformers and Resistors for soft start equipment

Type	Code n°	Description	Application	Packaging	Pack size
	8173045	Resistor 2.2 ohm, 140 W	SCR03 soft start kit	Single pack	1

Acoustic hoods

Type	Code n°	Description	Application	Packaging	Pack size
1 cyl	7755001	Acoustic hood for 1 cyl	NTZ048-068	Single pack	1
2 cyl	7755002	Acoustic hood for 2 cyl	NTZ096-136	Single pack	1
4 cyl	7755003	Acoustic hood for 4 cyl	NTZ215-271	Single pack	1

Mounting kits

Type	Code n°	Description	Application	Packaging	Pack size
	8156001	Accessory bag with Mounting kit 1 & 2 cyl	NTZ048-136	Single pack	1
	8156007	Accessory bag with Mounting kit 4 cyl	NTZ215-271	Single pack	1

Terminal boxes, covers & T-block connectors

Type	Code n°	Description	Application	Packaging	Pack size
	8156134	Cover 80 x 96 mm ; clamp	NTZ048-136 (except 136-1)	Multipack	10
	8173230	T-block 52 x 57 mm, 3 screws H10-32 UNF9.5	NTZ136-1, NTZ215-271	Multipack	10
	8156135	Covers 96 x 115 mm, clamp	NTZ136-1, NTZ215-271	Multipack	10

Lubricants / oils

Type	Code n°	Description	Application	Packaging	Pack size
160PZ	7754019	POE lubricant, 160PZ, 1 litre can	NTZ with R404A, R507	Multipack	12
160PZ	7754020	POE lubricant, 160PZ, 2 litre can	NTZ with R404A, R507	Multipack	8

Miscellaneous

Type	Code n°	Description	Application	Packaging	Pack size
	8156145	Oil sight glass gasket (black)	1-2-4 cyl models produced since 2002	Multipack	10
	8156019	Oil sight glass + gaskets	1-2-4 cylinder VE versions	Multipack	4
	8154001	Blue spray paint	All models	Single pack	1



Danfoss Commercial Compressors is a worldwide manufacturer of compressors and condensing units for refrigeration and HVAC applications. With a wide range of high quality and innovative products we help your company to find the best possible energy efficient solution that respects the environment and reduces total life cycle costs.

We have 40 years of experience within the development of hermetic compressors which has brought us amongst the global leaders in our business, and positioned us as distinct variable speed technology specialists. Today we operate from engineering and manufacturing facilities spread across three continents.



Performer Variable Speed scroll compressors



Performer Air Conditioning scroll compressors



Performer Heat Pump scroll compressors



Maneurop Variable Speed reciprocating compressors



Performer Refrigeration scroll compressors



Maneurop Reciprocating Compressors



Optyma Plus Condensing Units



Optyma Condensing Units

Our products can be found in a variety of applications such as rooftops, chillers, residential air conditioners, heatpumps, coldrooms, supermarkets, milk tank cooling and industrial cooling processes.

member of:



www.asercom.org

Danfoss Commercial Compressors <http://cc.danfoss.com>

Danfoss can accept no responsibility for possible errors in catalogues, brochures and other printed material. Danfoss reserves the right to alter its products without notice. This also applies to products already on order provided that such alterations can be made without consequential changes being necessary in specifications already agreed. All trademarks in this material are property of the respective companies. Danfoss and the Danfoss logotype are trademarks of Danfoss A/S. All rights reserved.

FRCC.PC.002.A3.02 - June 2011 - replace FRCC.PC.002.A2.02 February 2007

Copyright Danfoss Commercial Compressors - 06/2011